

Flat Pattern view  
SCALE: 1:2

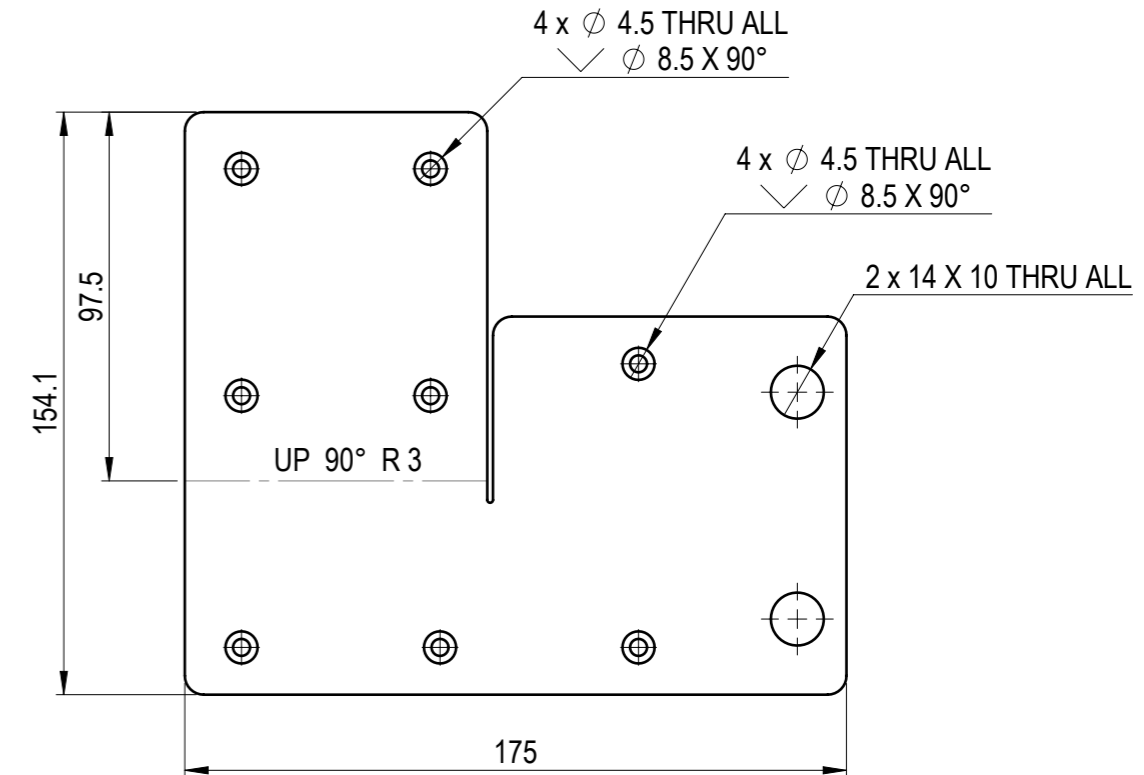

A-A  
SCALE: 2 : 1

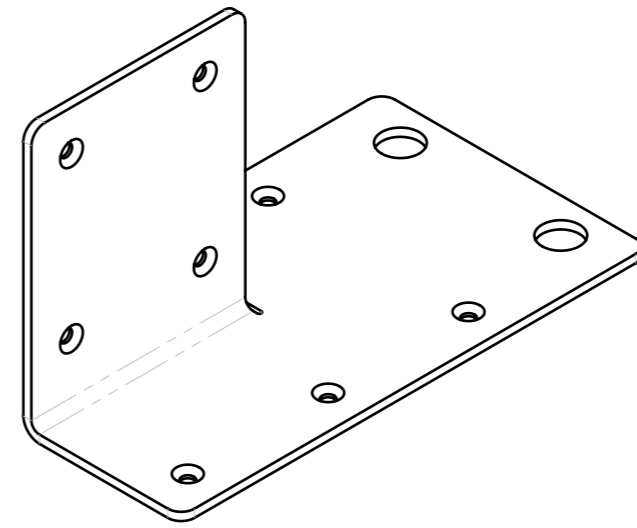
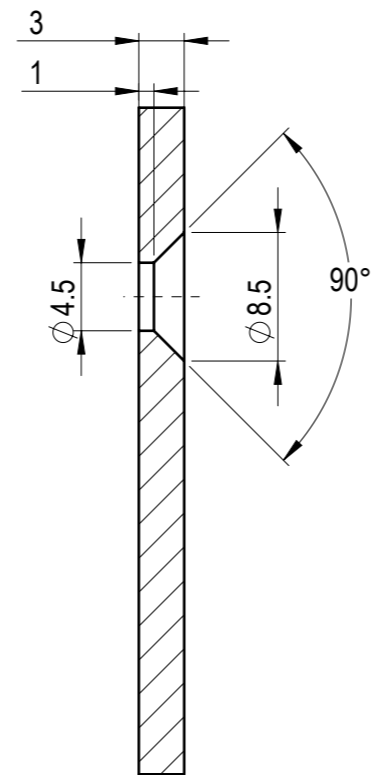
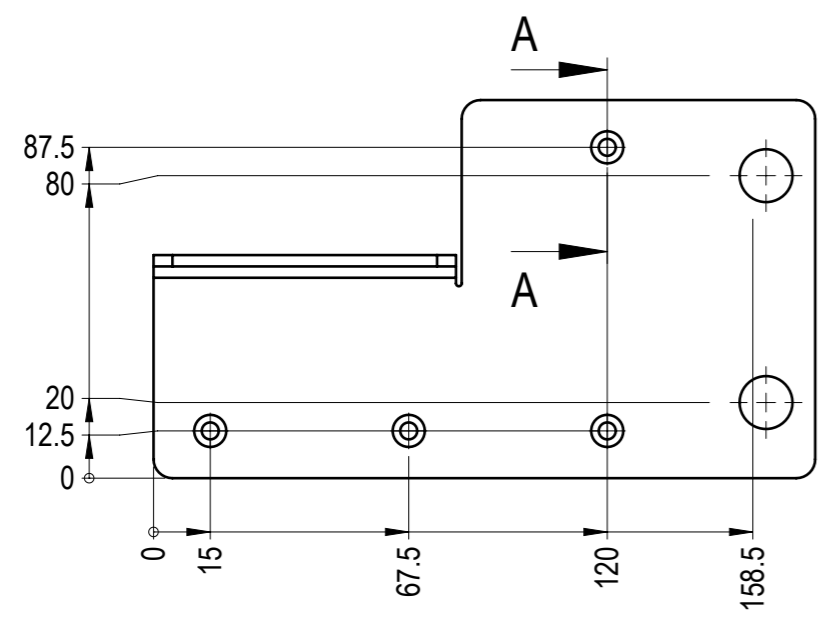

SHEET METAL INFORMATION	
Length, mm	175
Width, mm	154.1
Thickness, mm	3
Inside Bend Radius, mm	3
K-Factor	0.5
No. of Bends	1

Other dimensions from .DXF file.

	MATERIAL	WEIGHT	DEBURR AND BREAK SHARP EDGES		REVISION	DATE
	S355JR	0.496 Kg	DO NOT SCALE DRAWING			21.03.2025
	SURFACE PROTECTION	MACHINING	THERMAL CUTTING	WELDING	SCALE	FORMAT
	HDG EN ISO 1461	ISO 2768 mK	ISO 9013 221	ISO 13920 BF	1:2	A3
	NAME	SIGNATURE	PART NO.			
Designed by	M. Supols		105-11330-01			
Drawn by	M. Supols		Support plate 1			
Technical ref.			DESCRIPTION			SHEET 1/1